



BC315

QUICK FACTS

THE ORIGINAL LIGHTWEIGHT STARTER

imitated — but never equaled. First introduced in 1986, the B&C Starter for Lycoming engines has provided dependable service for thousands of satisfied customers; and it remains the benchmark of reliability and genuine value. Compared with the Prestolite-type starter for 4- and 6-cylinder engines, the B&C Starter will save 7 lbs. (or 24 lbs. for the OEM starter for 8-cylinder engines!) — not to mention that it has greater torque and eliminates the troublesome Bendix drive. Compared with the current OEM starter for the same

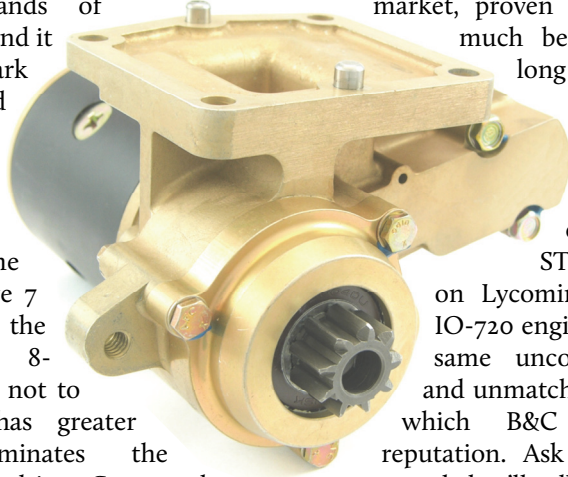

engines, it provides greater durability in challenging conditions and superior quality. While there are cheaper starters on the market, proven reliability offers a much better value in the long term. The B&C Starter is available in a number of configurations to fit a wide variety of applications. STC/PMA approved on Lycoming O-235 through IO-720 engines. All feature the same uncompromised value and unmatched reliability upon which B&C has built its reputation. Ask anyone who has one and they'll tell you: nothing else measures up to a B&C.

UNMATCHED RELIABILITY BEGINS HERE

Designing any product involves choices. Balancing quality materials with production costs, and (in the case of aviation) balancing ruggedness with weight — every choice involves a cost. Sometimes those costs are clearly visible; sometimes they are not.

When it comes to lightweight Starters, what's unseen often makes a big difference in reliability and performance. Consider the materials that go into one, for example. Bushings, unsealed needle bearings, plastic reduction gears, permanent magnet motors — they're all choices other manufacturers have embraced. And while they may not advertise that these choices cut production expenses, or reduce only a fraction of a pound, they're not without hidden costs.

All too frequently, such choices become

compromises that pass the "point of diminishing returns." That's when failures in the field, spotty reliability, and a shortened service-life show up — and that's unacceptable, as far as we're concerned.

The B&C Starter uses only sealed heavy-duty ball bearings, all-metal gears, and an efficient series-wound motor. There are no shortcuts on quality. Every choice matters. True, quality materials do cost more to make and to obtain; sometimes they weigh a bit more. But they are well worth it. Our unmatched reliability begins here.



FEATURES

- Sealed Heavy-Duty Ball Bearings (no bushings or needle bearings)
- All-Metal Gears (no plastic gears)
- Electro-Mechanical Pinion Actuation (no Bendix drive)
- Efficient Series-Wound Motor (no permanent magnet motor)
- Weight: 10.2 lbs.
- STC/PMA: Lycoming O-235 to IO-720
- Unmatched Reliability

BANDC.COM

PRICING

BC315-100-1, 122 Ring Gear, 12V (STC/PMA)	\$795
BC315-100-2, 149 Ring Gear, 12V (STC/PMA)	\$795
BC315-100-3, 122 Ring Gear, 24V (STC/PMA)	\$865
BC315-100-4, 149 Ring Gear, 24V (STC/PMA)	\$865
BC315-100-6, 149 Ring Gear, Counter-Rotating, 12V (STC/PMA)	\$885
BC315-100-8, 149 Ring Gear, Counter-Rotating, 24V (STC/PMA)	\$885

B&C STARTER DIMENSIONS

LARGE CABLE FROM STARTER SOLENOID ATTACHES HERE

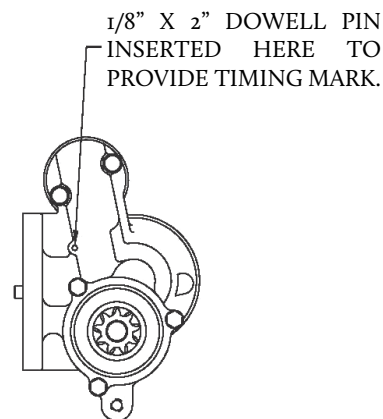
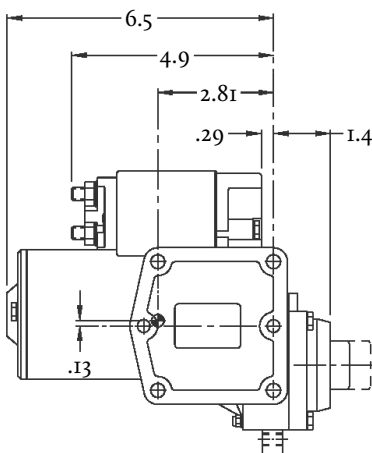
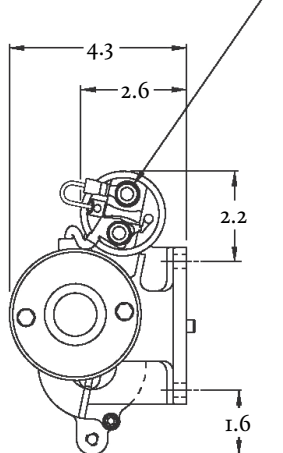

GETTING TO KNOW YOUR RING GEAR

Lycoming engines have used one of two starter ring gears over the years, each with a different number of teeth per inch (this is also known as “diametral pitch,” or “D.P.” for short). When selecting a replacement starter, it is crucial that the pitch of the starter pinion gear matches that of the engine ring gear precisely in order to avoid equipment damage.

As a general rule, early 4-cylinder engines manufactured prior to the mid-1960’s such as the O-290, O-235, early O-320’s, and the 8-cylinder IO-720, utilized ring gears with 122 teeth, or a 10/12 D.P. Later O-320’s, and the O-360 and O-540 have ring gears with 149 teeth, or a 12/14

D.P. Unfortunately, *engine manufacturing date alone is insufficient to guarantee the present ring gear in use*, since many engines may have had these replaced in their 40+ years in service. This is only a general indicator.

The actual shape of the gear “teeth” is

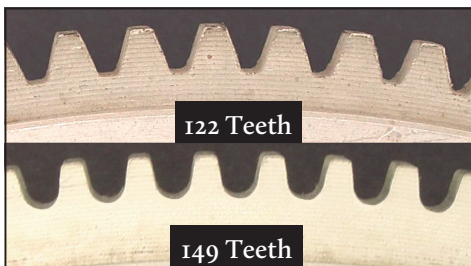

another useful general indicator, as the 122 tooth ring gear has V-shaped teeth, and the 149 tooth ring gear has U-shaped teeth (see photos at left). Close observation of the engine ring gear in question should suggest one of these two shapes, though heavy wear can obscure this visual indicator.

If either of these general indicators leave room for doubt, it is always advisable to simply count the number of ring gear teeth. In some cases, there is no better way to remove uncertainty than this — a small investment to insure a trouble-free (and worry-free) starter replacement.

SELECTING A B&C STARTER FOR YOUR APPLICATION

The B&C Starter for Lycoming engines is available in numerous configurations to suit a variety of applications. Configuration options include — 12 or 24 volts; 122 or 149 ring gear teeth; standard- or counter-rotating. All feature the same “No Compromises” construction that has made the B&C Starter the benchmark of long-term reliability and genuine value.

Voltage	Number of Ring Gear Teeth	Diametral Pitch (D.P.)	Engine Rotation	B&C Model Number
12	122	10/12	Standard	BC315-100-1
12	149	12/14	Standard	BC315-100-2
24	122	10/12	Standard	BC315-100-3
24	149	12/14	Standard	BC315-100-4
12	149	12/14	Counter	BC315-100-6
24	149	12/14	Counter	BC315-100-8