



123 East 4th St, P.O. Box "B" · Newton KS 67114-0894
Telephone (316) 283-8000 · Fax (316) 283-7400

The B&C Standby Alternator System for the Piper PA32

The B&C Standby Alternator system offers improved safety of flight for owners of Piper PA32 aircraft, with ease of operation and exceptional dependability. STC/PMA approved for installation on all Piper PA32, Cherokee Six, Lance and Saratoga models (including those with turbocharged engines). Eligible serial numbers are detailed on page 3.



In operation, the B&C Standby Alternator system monitors the aircraft bus voltage in the background, automatically signaling its operation to the pilot through a panel-mounted annunciator light (which also doubles as a standby alternator load monitor). If the primary alternator should fail in flight, the Standby Alternator system will sense the resulting drop in bus voltage and automatically activate. Rated to provide 20 amps of power to support continued flight, if load requirements exceed 20 amps the panel-mounted annunciator will flash, alerting the pilot to the condition. Reducing load usage to 20 amps or less will cause the annunciator to cease flashing and illuminate in a steady state. The pilot may choose equipment needed for the given flight conditions by simply keeping the total load below the flashing point of the

annunciator. This will reserve battery energy for transient loads, (gear, flaps, landing lights, etc.) during approach. Loads may be beyond the flashing point of the annunciator for up to five (5) minutes without damaging the standby alternator.

Installation Notes

The B&C Standby Alternator is mounted on the hydraulic accessory drive pad on the Lycoming “dual mag” (2-in-1 magneto) drive engines. The BC410 will not fit turbocharged aircraft with the TIO-540-S1AD powerplant.

On engines with two separate magnetos, the Standby Alternator is mounted on the vacuum pump drive and the vacuum pump is re-located to the hydraulic accessory drive pad. Lycoming parts needed to complete the hydraulic accessory drive are not included in the installation kit and must be purchased separately.

Panel mounted equipment includes a STBY ALT ON annunciator light, a STBY ALT rocker switch (purchased separately to match the existing switches) and three standard pull-type circuit breakers (1 amp, 5 amp and 40 amp). Appropriate placards are provided for each panel mounted device. The regulator is mounted in the area between the instrument panel and the firewall.

B & C Specialty Products Inc.
STC No. SA01066WI
PA32 Standby Alternator Approved Models List

| Model | Model Name | Serial Numbers |
|---------------------|---|---|
| PA-32-260 | CHEROKEE SIX - 260 | 32-03, 32-04, 32-1 THRU 32-1297, 32-710001 THRU 32-780008 |
| PA-32-300 | CHEROKEE SIX - 300 | 32-15, 32-21, 32-40000 THRU 32-40974, 32-7140001 THRU 32-7940290 |
| PA-32S-300 | CHEROKEE SIX - 300 SEA PLANE | 32S-15, 32S-40000 THRU 32S-40974, 32S-7140001 THRU 32S-7240137 |
| PA-32R-300 | LANCE | 32R-7680001 THRU 32R7880068 |
| PA-32RT-300 | LANCE II | 32R-7885002 THRU 32R-7985106 |
| PA-32R-301 | SARATOGA SP | 32R-8013001 THRU 32R-8613006, 3213001 THRU 3213028, 3213030 THRU 3213041 |
| PA-32R-301 | SARATOGA II HP | 3213029, 3213042 THRU 3213103 (14V), 3246001 THRU 3246017 (14V), 3246018 & UP (28V) |
| PA-32-301 | SARATOGA | 32-8006002 THRU 32-8606023, 3206001 THRU 3206019, 3206042 THRU 3206044, 3206047, 3206050 THRU 3206055, 3206060 |
| PA-32R-301T | SARATOGA II TC | 3257001 & UP |
| PA-32-301XTC | PIPER 6XT | 3255001 & UP |
| PA-32-301FT | PIPER 6X | 3232001 & UP |

Supplemental Type Certificate

SAMPLE

Number SA01066WI

This certificate issued to B & C Specialty Products, Inc.
123 E. 4th Street
Newton, KS 67114-0894

certifies that the change in the type design for the following product with the limitations and conditions therefor as specified hereon meets the airworthiness requirements of Part 3 of the Civil Air Regulations.

Original Product - Type Certificate Number : A3SO

Make : Piper

Model : PA-32-260, PA-32-300, PA-32S-300, PA-32R-300, PA-32RT-300,
PA-32R-301, PA-32-301, PA-32R-301T, PA-32-301T, PA-32RT-300T, PA-32-301XTC, PA-32-301FT

Description of Type Design Change: Installation of B&C Specialty Products BC410-1 Standby Alternator System. Data Required: (1) B&C Specialty Products, Inc. Drawing List No. 410LST3.DOC, Revision (-), dated June 4, 2001; (2) B&C Specialty Products Document No. FMS410-3, FAA Approved Airplane Flight Manual Supplement, dated April 3, 2002; or later FAA Approved Revisions to (1) or (2).

Limitations and Conditions: Compatibility of this design change with previously approved modifications must be determined by the installer.

If the holder agrees to permit another person to use this certificate to alter the product, the holder shall give the other person written evidence of that permission.

This certificate and the supporting data which is the basis for approval shall remain in effect until surrendered, suspended, revoked or a termination date is otherwise established by the Administrator of the Federal Aviation Administration.

Date of application : June 7, 2001

Date reissued :

Date of issuance : April 3, 2002

Date amended : November 6, 2006



By direction of the Administrator

Harvey E. Nero
(Signature)

Harvey E. Nero
FAA Program Manager
Wichita Aircraft Certification Office

(Title)

Any alteration of this certificate is punishable by a fine of not exceeding \$1,000, or imprisonment not exceeding 3 years, or both.

| REV | DATE | DESCRIPTION |
|-----|----------|--|
| A | 8/26/97 | ADDED 24 DEG DIMENSION |
| B | 5/20/98 | REMOVED SPLINE CALLOUT; ADDED 4.59 DIA & REF. NOTE |
| C | 8/18/99 | TBD WAS 1600 HRS. |
| D | 11/27/06 | ADDED -2 VERSION FOR PT6 |

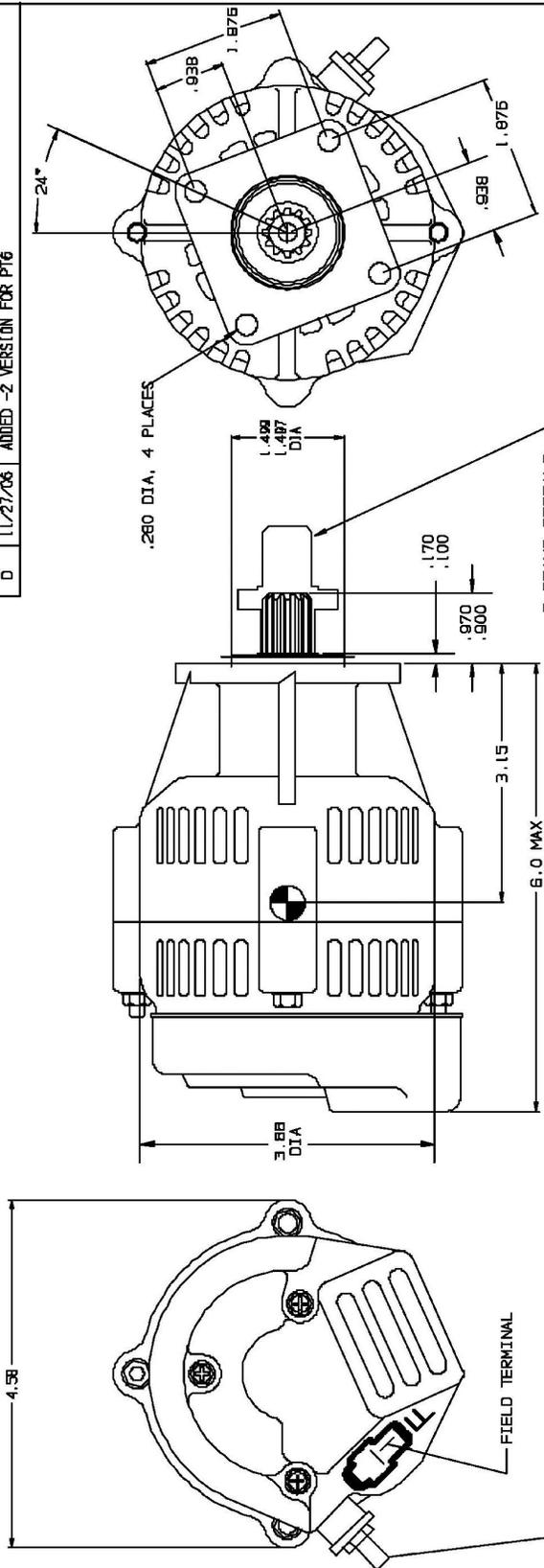

NOTE: 1. ALL DIMENSIONS FOR REFERENCE ONLY
 2. RECOMMENDED INTERVAL BETWEEN OVERHAUL IS 1700 HRS.

-1 ALTERNATOR 14/28V, 20 AMP

WEIGHT: 5.72 LBS.
 MAX STATOR TEMP: 300° F
 FOR USE ON AND 20000 ACCESSORY PAD.
 ALL DIMENSIONS ARE REFERENCE ONLY
 OVERHANG MOMENT 18.0 IN-LBS.
 MAX CONTINUOUS RPM: 10,000

| REV | DATE | DESCRIPTION |
|-----|-----------|--------------------------------|
| 1 | 410-100-2 | ALTRNTR ASSY, 14/28V, 20A, PT6 |
| 1 | 410-100-1 | ALTERNATOR ASSY, 14/28V, 20A |
| -1 | | ALTERNATOR, 14/28V, 20A |
| -2 | -1 | PART NO. |
| | | USED ON |
| | | UNLESS OTHERWISE SPECIFIED |
| | | DIMENSIONS ARE IN INCHES |
| | | TOLERANCES ARE: |
| | | DECIMALS = ± .010 |
| | | FRACTIONS = ± .0005 |
| | | ANGLES = 20.0 DEGREES |
| | | ENGINEER NAME DATE |
| | | ENGINEER NAME DATE |
| | | DATE 8/31/99 |
| | | SCALE |
| | | JOB NO. |
| | | BC410 |
| | | DATE 11/27/06 |
| | | SHEET 1 OF 1 |

B & C Specialty Products
 P.O. Box B, Newton, Kansas 67114
 TITLE
 ENVELOPE DRAWING
 AIRCRAFT ALTERNATOR,
 14/28 VOLT, 20 AMP
 DRAWING NO.
 REVISED D

| SYMBOL | REVISION | DRAWN | APPROVED |
|--------|---|-------|----------|
| C | ADDED PA-32R-301T, PA-32-301T, PA-32RT-300T, PA-32-301XTC, PA-32-301FT UPDATED S/N'S ON PA-32-301 | TH | 10/11/06 |
| D | 1. CHANGED PANEL CUTOOUT DIM'S ON PG. 4 2. ADDED ITEM 28 ON PAGE 1 3. ADDED KIT PART NUMBERS: 410-501-1-KIT 410-501-2-KIT | WB | 11/9/12 |

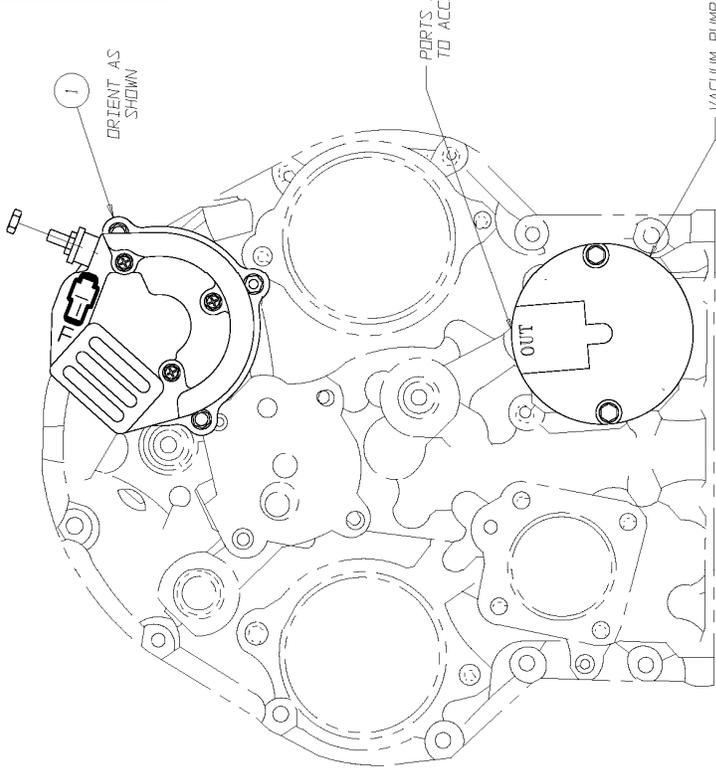

PORTS MAY BE ORIENTED AS NECESSARY TO ACCOMMODATE VACUUM PLUMBING

VACUUM PUMP

ALTERNATOR INSTALLATION INSTRUCTIONS (D-540-E485, ID-540-K1A5, ID-540-K1G5, & T10-540-AH1A ENGINES):

- DISCONNECT VACUUM PUMP. REMOVE VACUUM PUMP FROM ACCESSORY ADAPTER. REMOVE COVER PLATE FROM LOWER ACCESSORY CASE DRIVE AREA. RETAIN ALL HARDWARE. REMOVE ALL OLD GASKET MATERIAL FROM ALL GASKET SURFACES BEING CAREFUL NOT TO DAMAGE ALUMINUM SURFACES.
- INSTALL HYDRAULIC PUMP DRIVE ADAPTER ON LOWER ACCESSORY CASE DRIVE PAD PER LYCOMING SERVICE MANUAL. D-540 HYDRAULIC DRIVE CONSISTS OF:
HOUSING, LYC P/N 71675; GEAR, LYC P/N 72964
THRUST WASHER, LYC P/N 71596; SEAL, LYC P/N 06A19956
GASKET, LYC P/N 66315
- PLACE A NEW GASKET, ITEM 14, ON STUDS OF EACH ACCESSORY DRIVE ADAPTER. INSTALL VACUUM PUMP THAT IS SUITABLE FOR CLOCKWISE ROTATION ON LOWER ACCESSORY DRIVE ADAPTER. INSTALL ALTERNATOR ON UPPER ACCESSORY DRIVE ADAPTER WITH OUTPUT POST Clocked TO THE POSITION SHOWN.
- SECURE THE VACUUM PUMP AND ALTERNATOR WITH NUTS, LOCKWASHERS, AND FLAT WASHERS RETAINED FROM STEP 1 ABOVE. TORQUE NUTS TO 90 - 110 IN-LBS.
- RE-PLUMB VACUUM HOSES TO APPROPRIATE PORTS OF VACUUM PUMP.

| ITEM | USED ON | PART NO. | DESCRIPTION |
|----------------------------------|---------|----------|-------------|
| | | | |
| UNLESS OTHERWISE SPECIFIED | | | |
| DIMENSIONS ARE IN INCHES | | | |
| TOLERANCES ARE: | | | |
| FRACTIONS: XX/YY ± 0.005 | | | |
| DECIMALS: XXX ± 0.005 | | | |
| ANGLES: ° ± 0.5 DEGREES | | | |
| ENGINEER | NAME | DATE | |
| DRAWN | TH | 5/14/01 | REVISION |
| CHECKED | TH | 5/14/01 | DATE |
| PROJECT | | | |
| TITLE | | SCALE | |
| B & C Specialty Products | | FULL | |
| P.O. Box B, Newton, Kansas 67114 | | JOB NO. | |
| INSTALLATION, BC410 ON | | PAGE 2 | |
| PIPER PA32/32R SERIES ACFT | | | |
| DRAWING NO. 410-506 | | | |

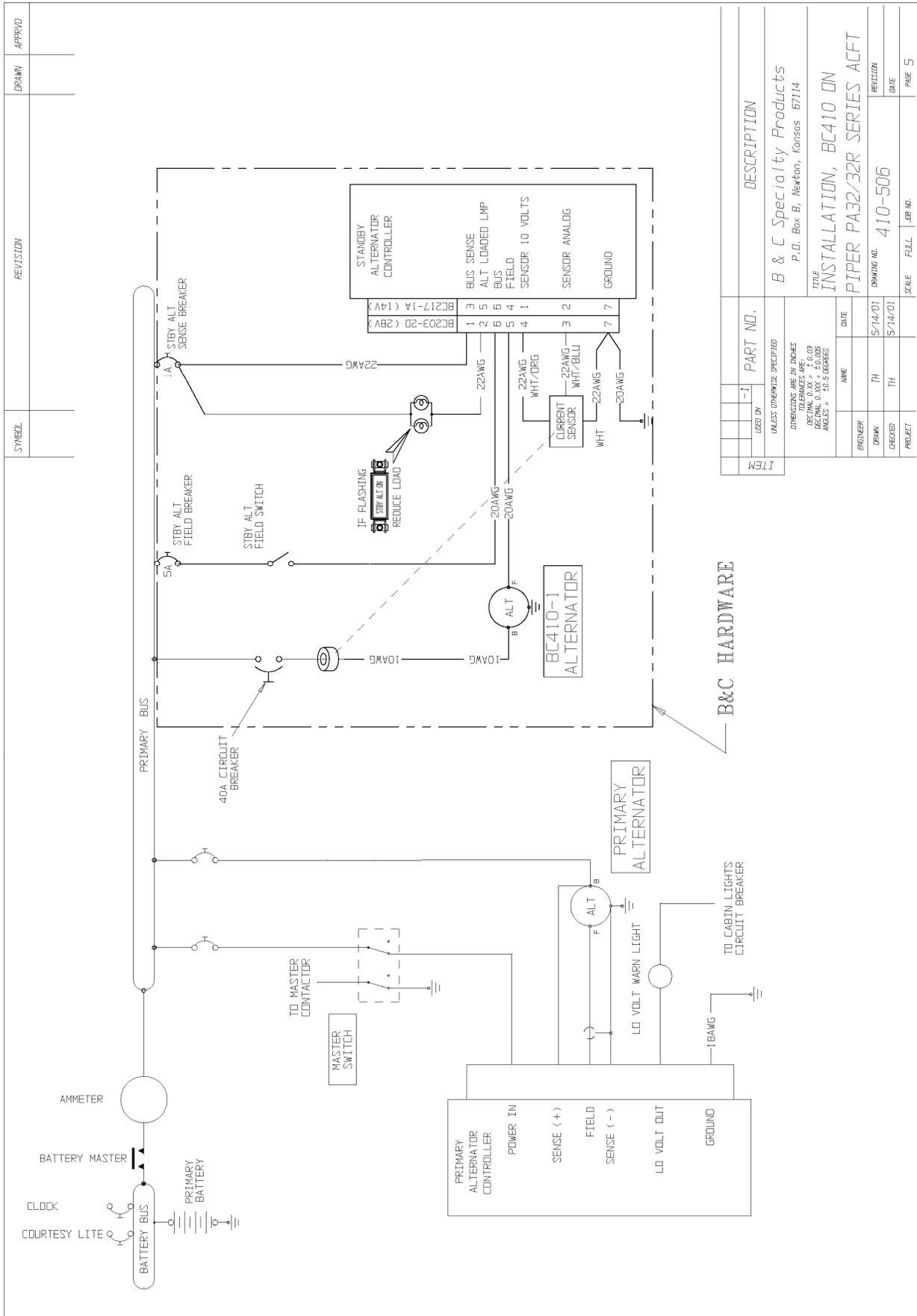

B&C HARDWARE

| ITEM | QTY | DESCRIPTION |
|----------------------------|------|-------------|
| | 1 | PART NO. |
| UNLESS OTHERWISE SPECIFIED | | |
| DIMENSIONS ARE IN INCHES | | |
| TOLERANCES ARE: | | |
| FRACTIONS: ±0.005 | | |
| DECIMALS: ±0.001 | | |
| ANGLES: ±0.5 DEGREES | | |
| ENGINEER | DATE | |
| DRAWN | TH | 5/14/01 |
| CHECKED | TH | 5/14/01 |
| PROJECT | | |
| DRAWING NO. 410-506 | | JOB NO. |
| SCALE | FULL | PAGE 5 |

DESCRIPTION

B & C Specialty Products
P.O. Box B, Newton, Kansas 67114

TITLE
INSTALLATION, BC410 ON
PIPER PA32/32R SERIES ACFT

Range of Applications

The B&C Specialty Products Standby Alternator System has been installed in thousands of certified aircraft over the past 20 years. It has been factory-installed on the Mooney Ovation and Acclaim since June 1996; on the Beech Bonanza since mid-2000; and on the Quest Kodiak since 2008. B&C also holds an STC for installation of the Standby Alternator system in Cessna 210 aircraft and has cooperated on an STC/PMA installation for Cessna 182 and 206 aircraft with Lycoming powerplants (contact us for details).

For individuals interested in obtaining one-time field approvals on aircraft not yet covered by the STC, a general system wiring diagram has been provided in this brochure to assist in these efforts. We will continue to work on STC's for other models. Please let us know if you are interested in the Standby Alternator system for your aircraft – and feel free to call if you have any questions.

Pricing

| | |
|--|-----------|
| BC410-1 Alternator and Regulator w/ STC (specify 14v or 28v) | \$2575.00 |
| 410-506 Installation Kit (specify 14v or 28v) | \$550.00 |